



# More Precision

**wireSENSOR** // Draw-wire displacement sensors





- Robust aluminium profile housing
- Customised versions for OEM
- Potentiometer, current and voltage output

Model P60 Output P

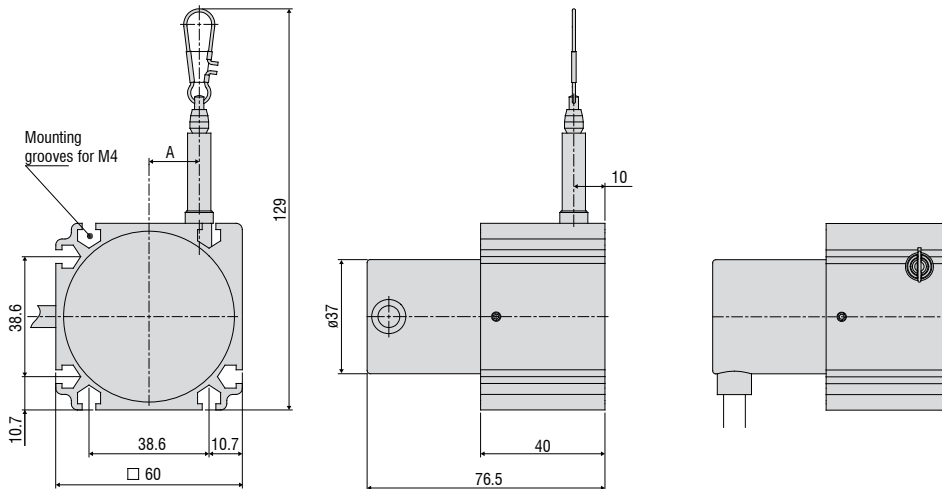

Measuring range (mm)	A (mm)
100 / 300 / 500 / 1000	16.15
150 / 750 / 1500	24.2

Model P60 Output U/I

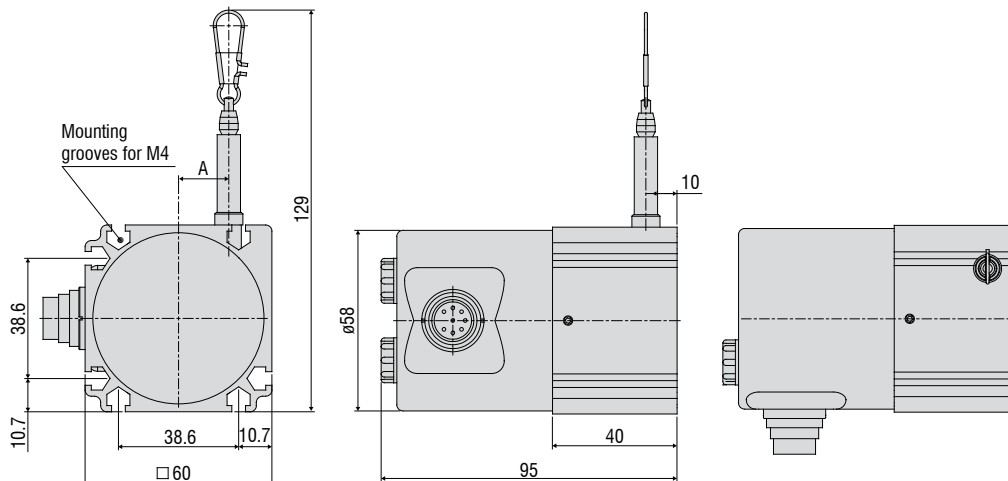

Measuring range (mm)	A (mm)
100 / 300 / 500 / 1000	16.15
150 / 750 / 1500	24.2

Model	WDS-100-P60	WDS-150-P60	WDS-300-P60	WDS-500-P60	WDS-750-P60	WDS-1000-P60	WDS-1500-P60	
Output	P/U/I							
Measuring range	100mm	150mm	300mm	500mm	750mm	1000mm	1500mm	
Linearity	±0.1% FSO	-	-	-	±0.5mm	±0.75mm	±1mm	±1.5mm
	±0.25% FSO	-	-	±0.75mm	-	-	-	-
	±0.5% FSO	±0.5mm	±0.75mm	-	-	-	-	-
Resolution	quasi infinite							
Sensor element	conductive plastic/ wire potentiometer		hybrid potentiometer					
Temperature range	-20 ... +80°C							
Material	housing	aluminium						
	draw wire	coated polyamide stainless steel (ø 0.45mm)						
Sensor mounting	mounting grooves in the housing							
Wire mounting	wire clip							
Wire acceleration	appr. 10 - 15g (dependent upon measuring range)							
Wire retraction force (min)	6.5N	4.5N	6N	6N	4N	5N	3.5N	
Wire extension force (max)	7.5N	5.5N	7.5N	7.5N	5.5N	7.5N	5.5N	
Protection class	IP 65 (only if connected)							
Vibration	20g, 20Hz - 2kHz							
Mechanical shock	50g, 10ms							
Electrical connection	P	integrated cable, radial, 1m						
	U, I	flange connector, radial, 8-pin, DIN45326						
Weight	appr. 370g							

FSO = Full Scale Output

Specifications for analogue outputs on page 51.

## Article description

WDS -	100 -	P60 -	CR -	P
				Output option: P = potentiometer (with connection CR) U = voltage (with connection SR) I = current (with connection SR)
				Connection: SR: radial plug CR: integrated cable, radial, 1m
				Model P60
				Measuring range in mm



- Robust aluminium profile housing
- Customised versions for OEM
- Incremental/absolute encoder

Model P60

MR (mm)	A (mm)
1000	16.15
1500	24.2

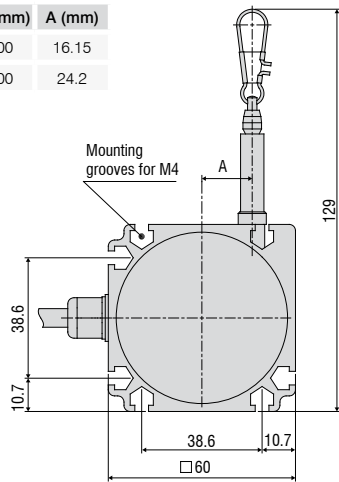

Output HTL/TTL

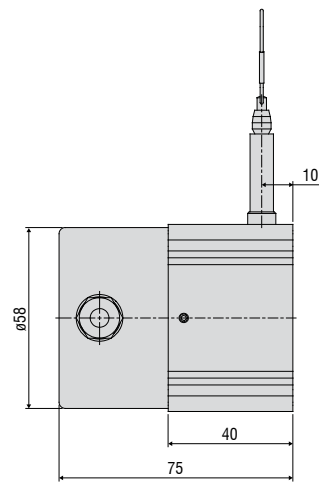

Output SSI

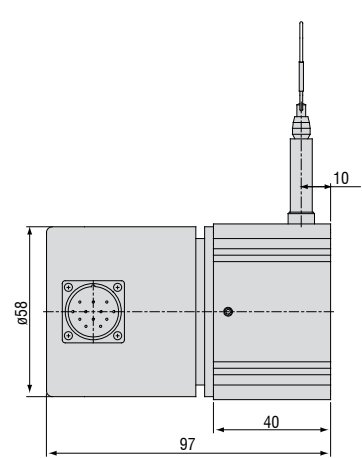

Model P60 Output CO/PB

MR (mm)	A (mm)
1000	16.15
1500	24.2

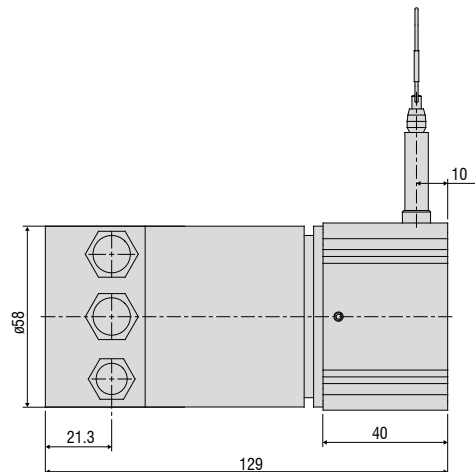
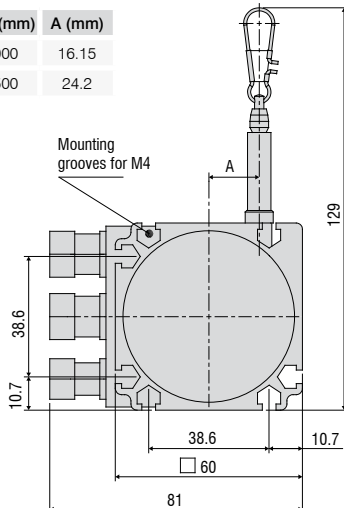

Model		WDS-1000-P60	WDS-1500-P60
Output		HTL, TTL, PB, CO, SSI	
Measuring range		1000mm	1500mm
Linearity	±0.02% FSO	±0.2mm	±0.3mm
Resolution	HTL, TTL	0.067mm (15 pulses/mm)	0.1mm (10 pulses/mm)
Resolution	SSI, PB, CO	0.012mm	0.018mm
Sensor element		incremental encoder	
Temperature range		-20 ... +80 °C	
Material	housing	aluminium	
	draw wire	coated polamide stainless steel (ø 0.45mm)	
Sensor mounting		mounting grooves in the housing	
Wire mounting		wire clip	
Wire acceleration		10g	15g
Wire retraction force (min)		5N	3.5N
Wire extension force (max)		7.5N	5.5N
Protection class		IP 65 (only if connected)	
Vibration		20g, 20Hz - 2kHz	
Mechanical shock		50g, 10ms	
Electrical connection	HTL, TTL	integrated cable, radial, 1m	
	SSI	flange connector, radial, 12-pin	
	PB, CO	bus cover	
Weight		appr. 1kg	

FSO = Full Scale Output

Specifications for digital outputs on page 52.

## Article description

WDS -	1000 -	P60 -	CR -	TTL
				Output option: HTL TTL CO: CANopen PB: Profibus DP SSI
				Connection: SR (Output SSI): radial plug CR (Output HTL, TTL): integrated cable, radial, 1m BH (Output CO, PB): bus cover
				Model P60
				Measuring range in mm



- Robust aluminium profile housing
- Customised versions for OEM
- Potentiometer, current and voltage output

Model P96 Output P

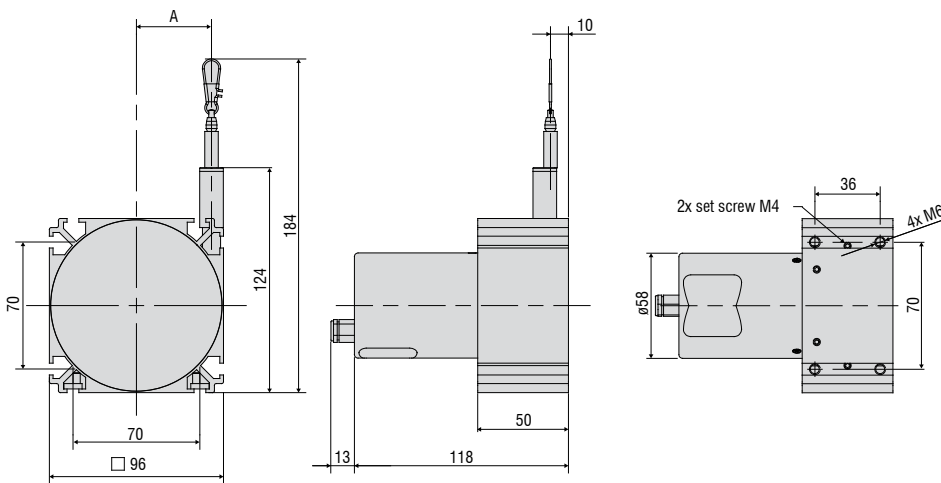

MR (mm)	A (mm)
2000	32
2500	41.4

Model P96 Output U/I

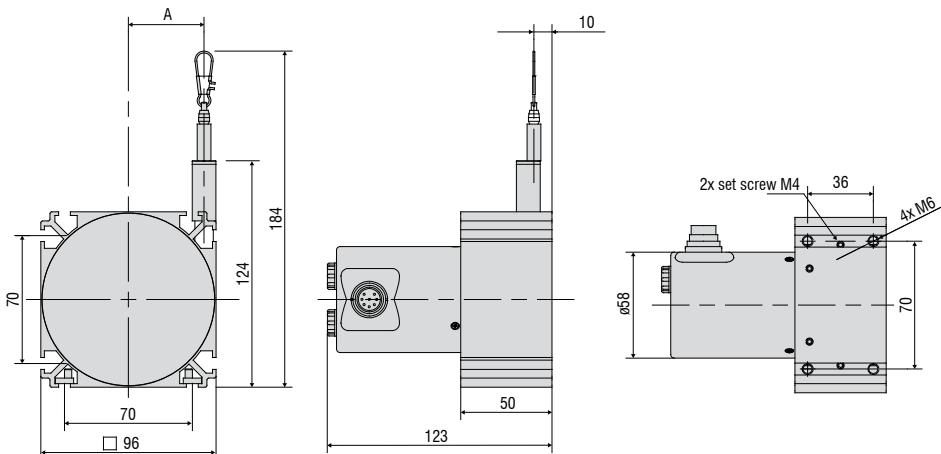

MR (mm)	A (mm)
2000	32
2500	41.4

Model	WDS-2000-P96	WDS-2500-P96
Output	P/U/I	
Measuring range	2000mm	2500mm
Linearity	±0.1% FSO	±2.5mm
Resolution	quasi infinite	
Sensor element	hybrid potentiometer	
Temperature range	-20 ... +80 °C	
Material	housing	aluminium
	draw wire	coated polamide stainless steel (ø 0.8mm)
Sensor mounting	slot nuts	
Wire mounting	wire clip	
Wire acceleration	8g	
Wire retraction force (min)	7.5N	5.5N
Wire extension force (max)	11N	9N
Protection class	IP 65 (only if connected)	
Vibration	20g, 20Hz - 2kHz	
Mechanical shock	50g, 10ms	
Electrical connection	P	integrated cable, radial, 1m
	U, I	flange connector, axial, 8-pin DIN45326
Weight	appr. 1.1kg	

FSO = Full Scale Output  
 Specifications for analogue outputs on page 51.

#### Article description

WDS -	2000 -	P96 -	CA -	P
				Output option: P = potentiometer (with connection CA) U = voltage (with connection SR) I = current (with connection SR)
				Connection: SR: radial plug CA: integrated cable, axial, 1m
				Model P96
				Measuring range in mm



- Robust aluminium profile housing

- Incremental / absolute encoder

Model P96

Output HTL/TTL

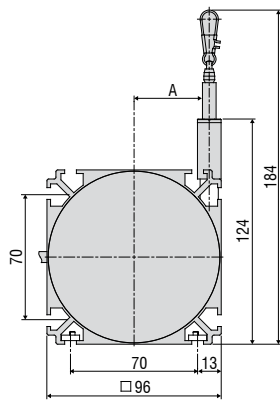

MR (mm)	A (mm)
2000	26
3000	41.4

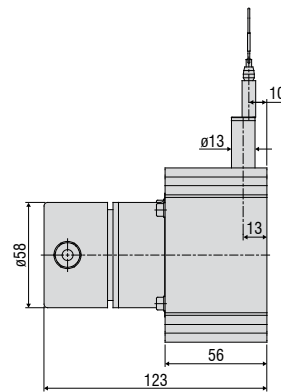
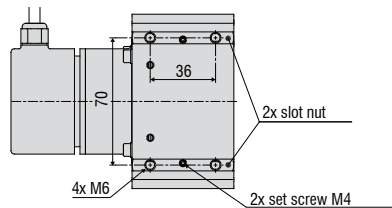

Output CO/PB

Output SSI

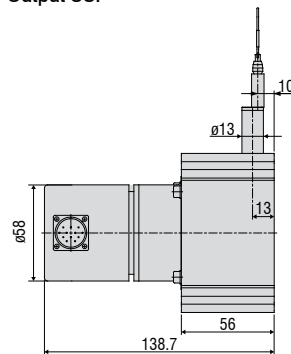
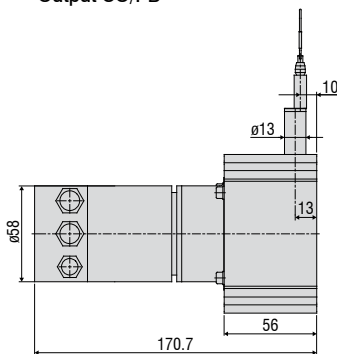



Model	WDS-3000-P96	
Output	HTL, TTL, SSI, PB, CO	
Measuring range	3000mm	
Linearity	±0.02% FSO	±0.6mm
Resolution	HTL, TTL	0.087mm (11.53 pulses/mm)
Resolution	SSI, PB, CO	0.032mm
Sensor element	incremental/absolute encoder	
Temperature range	-20 ... +80 °C	
Material	housing	aluminium
	draw wire	coated polamide stainless steel (ø 0.8mm)
Sensor mounting	slot nuts	
Wire mounting	wire clip	
Wire acceleration	7g	
Wire retraction force (min)	5.5N	
Wire extension force (max)	9N	
Protection class	IP 65 (only if connected)	
Vibration	20g, 20Hz - 2kHz	
Mechanical shock	50g, 10ms	
Electrical connection	HTL, TTL	integrated cable, radial, 1m
	SSI	flange connector, radial, 12-pin
	PB, CO	bus cover
Weight	appr. 1.7kg	

FSO = Full Scale Output

Specifications for digital outputs on page 52.

## Article description

WDS -	3000 -	P96 -	CR -	TTL
				Output option: HTL TTL CO: CANopen PB: Profibus DP SSI
				Connection: SR (Output SSI): radial plug CR (Output HTL, TTL): integrated cable, radial, 1m BH (Output CO, PB): bus cover
				Model P96
				Measuring range in mm

**Accessories:**

WE-xxx-M4	Wire extension with M4-wire connection, x=length
WE-xxx-Clip	Wire extension with eyelet, x=length
TR1-WDS	Pulley wheel, adjustable
TR3-WDS	Pulley wheel, fixed
GK1-WDS	Attachment head for M4
MH1-WDS	Magnetic holder for wire mounting
MH2-WDS	Magnetic holder for sensor mounting
MT-60-WDS	Mounting clamp for WDS-P60
FC8	Female connector for WDS, 8-pin
FC8/90	Female connector 90° for WDS
PC 3/8-WDS	Sensor cable, length 3m
PS 2020	(Power Supply 24 V / 2,5 A, Input 100 - 240 VAC, output 24 VDC / 2.5 A, for snap in mounting on DIN 50022 rail)
WDS-MP60	Mounting plate for P60 sensors

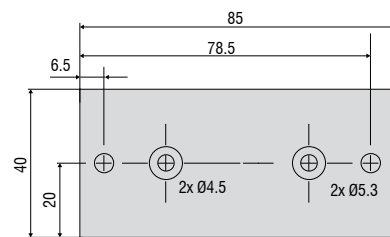
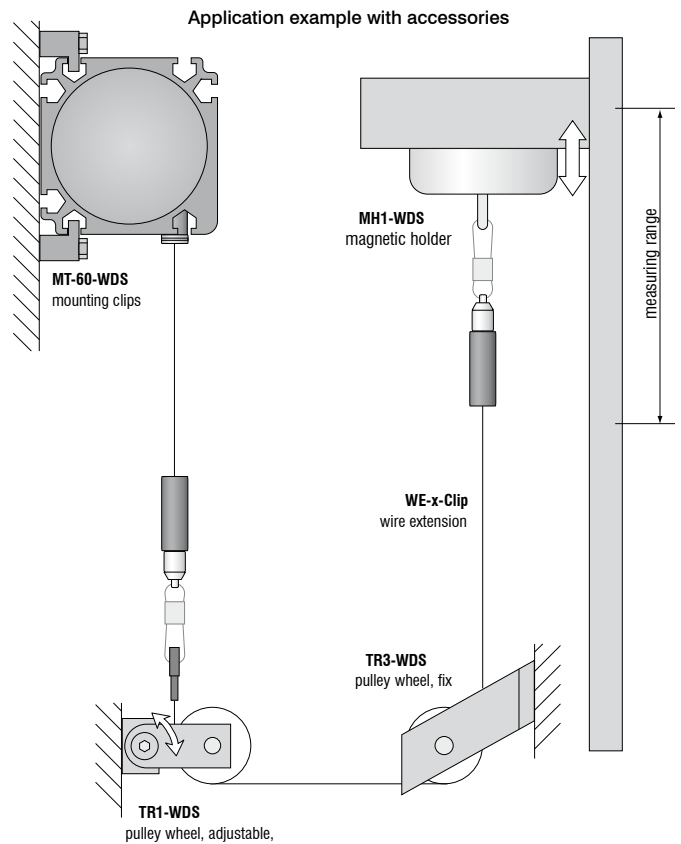

Mounting plate WDS-MP60

**Installation information:**

**Wire attachment:** The free return of the measurement wire is not permissible and it is essential that this is avoided during installation.

**Wire exit angle:**

When mounting a draw-wire displacement sensor, a straight wire exit ( $\pm 3^\circ$  tolerance) must be taken into account. If this tolerance is exceeded, increased material wear on the wire and at the wire aperture must be expected.

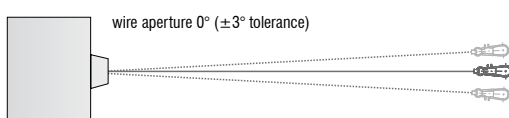

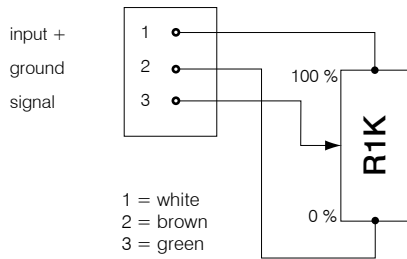

**Potentiometric output (P)**

Supply voltage	max. 32VDC at 1kOhm / 1 Wmax
Resistance	1kOhm $\pm 10\%$ (potentiometer)
Temperature coefficient	$\pm 0.0025\%$ FSO/ $^{\circ}$ C
Sensitivity	depends on measuring range individually shown on test report

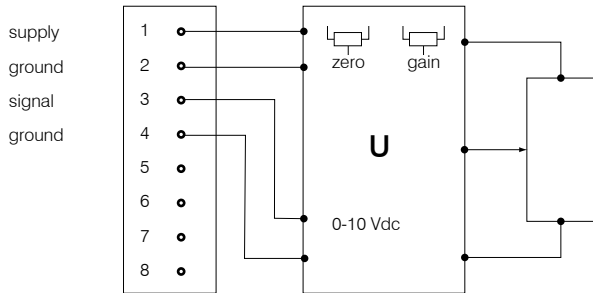

**Voltage output (U)**

Supply voltage	14 ... 27VDC (non stabilised)
Current consumption	max. 30mA
Output voltage	0 ... 10VDC Option 0 ... 5 / $\pm 5$ V
Load impedance	$> 5k\Omega$
Signal noise	$0.5mV_{eff}$
Temperature coefficient	$\pm 0.005\%$ FSO/ $^{\circ}$ C
Electromagnetic compatibility (EMC)	EN 50081-2 EN 50082-2

**Adjustment ranges**

Zero	$\pm 20\%$ FSO
Sensitivity	$\pm 20\%$

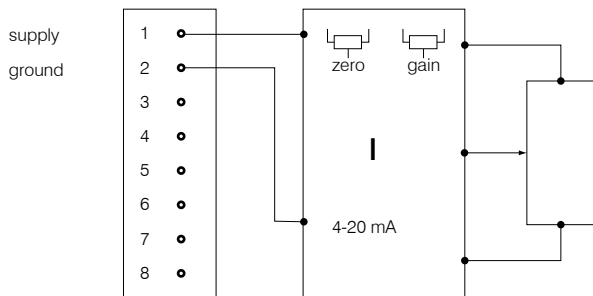

**Current Output (I)**

Supply voltage	14 ... 27VDC (non stabilised)
Current consumption	max. 35mA
Output current	4 ... 20mA
Load	$< 600\Omega$
Signal noise	$< 1.6\mu A_{eff}$
Temperature coefficient	$\pm 0.01\%$ FSO/ $^{\circ}$ C
Electromagnetic compatibility (EMC)	EN 50081-2 EN 50082-2

**Adjustment range**

Zero	$\pm 18\%$ FSO
Sensitivity	$\pm 15\%$

**Contact description**

1 UB	Encoder power supply connection
2 GND	Encoder ground connection. The voltage drawn to GND is UB.
3 Pulses +	Positive SSI pulse input. Pulse + forms a current loop with pulse -. A current of approx. 7 mA in direction of pulse + input generates a logical 1 in positive logic.
4 Data +	Positive, serial data output of the differential line driver. A High level at the output corresponds to logical 1 in positive logic.
5 ZERO	Zero setting input for setting a zero point at any desired point within the entire resolution. The zeroing process is triggered by a High pulse (pulse duration $\geq 100$ ms) and must take place after the rotating direction selection (UP/DOWN). For maximum interference immunity, the input must be connected to GND after zeroing.
6 Data -	Negative, serial data output of the differential line driver. A High level at the output corresponds to logical 0 in positive logic.
7 Pulses -	Negative SSI pulse input. Pulse - forms a current loop with pulse +. A current of approx. 7 mA in direction of pulse - input generates a logical 0 in positive logic.
8 / 10 <u>DATAVALID</u> <u>DATAVALID MT</u>	Diagnosis outputs DV and DV MT Jumps in data word, e.g. due to defective LED or photoreceiver, are displayed via the DV output. In addition, the power supply of the multiturn sensor unit is monitored and the DV MT output is set when a specified voltage level is dropped below. Both outputs are Low-active, i.e. are switched through to GND in the case of an error.
9 UP/DOWN	UP/DOWN counting direction input. When not connected, this input is on High. UP/ DOWN-High means increasing output data with a clockwise shaft rotating direction when looking at the flange. UP/ DOWN-Low means increasing values with a counter-clockwise shaft rotating direction when looking at the flange.
11 / 12	Not in use

**Pin assignment**

Pin	Cable colour	Assignment
1	brown	UB
2	black	GND
3	blue	Pulses +
4	beige	Data +
5	green	ZERO
6	yellow	Data -
7	violet	Pulses -
8	brown/yellow	<u>DATAVALID</u>
9	pink	UP/ DOWN
10	black/yellow	<u>DATAVALID</u> <u>MT</u>
11	-	-
12	-	-

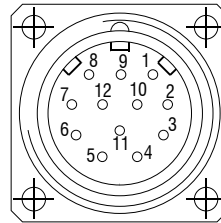

Please use leads twisted in pairs for extension cables.

**Inputs**

Control signals UP/DOWN and Zero

Level High	> 0.7 UB
Level Low	< 0.3 UB
Connection:	UP/DOWN input with 10kohms to UB, zeroing input with 10kohms to GND.
SSI pulse	

Optocoupler inputs for electrical isolation

**Outputs**

SSI data	RS485 driver	
Diagnostic outputs		
Push-pull outputs are short-circuit-proof		
Level High	> UB -3.5V	(with I = -20mA)
Level Low	$\leq 0.5V$	(with I = 20mA)

CANopen features	
Bus protocol	CANopen
Device profile	CANopen - CiA DSP 406, V 3.0
CANopen Features	Device Class 2, CAN 2.0B
Operating modes (with SDO progr.)	<p>Polling Mode (asynch, via SDO)</p> <p>Cyclic Mode (asynch-cyclic) The encoder cyclically sends the current process actual value without a request by a master. The cycle time can be parameterised for values between 1 and 65535 ms.</p> <p>Synch Mode (synch-cyclic) The encoder sends the current actual process value after receiving a synch telegram sent by a master. The synch counter in the encoder can be parameterised so that the position value is not sent until after a defined number of synch telegrams.</p> <p>Acyclic Mode (synch-acyclic)</p>
Preset value	With the "Preset" parameter the encoder can be set to a desired actual process value that corresponds to the defined axis position of the system. The offset value between the encoder zero point and the mechanical zero point of the system is saved in the encoder.
Rotating direction	With the operating parameter the rotating direction in which the output code is to increase or decrease can be parameterised. Scaling The steps per revolution and the total revolution can be parameterised.
Scaling	The steps per revolution and the total revolution can be parameterised.
Diagnose	The encoder supports the following error messages: - Position and parameter error - Lithium cell voltage at lower limit (Multiturn)
Default setting	50kbit/s, node number 1

Baud rate	Setting Dip Switch		
	1	2	3
10kBit/s	OFF	OFF	OFF
20kBit/s	OFF	OFF	ON
50kBit/s	OFF	ON	OFF
125kBit/s	OFF	ON	ON
250kBit/s	ON	OFF	OFF
500kBit/s	ON	OFF	ON
800kBit/s	ON	ON	OFF
1MBit/s	ON	ON	ON

Contact description CANopen	
CAN_L	CAN Bus Signal (dominant Low)
CAN_H	CAN Bus Signal (dominant High)
UB	Supply voltage 10...30VDC
GND	Ground contact for UB
(Terminals with the same designation are internally interconnected)	

**Settings of user address for CANopen**  
 Address can be set with rotary switch. Example: User address 23

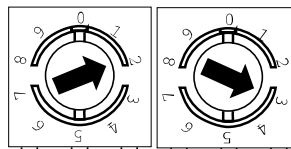
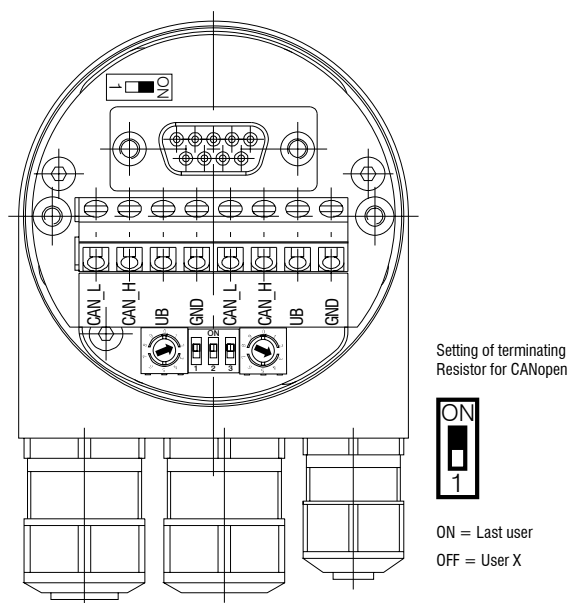

**Profibus-DP features**

Bus protocol	Profibus-DP
Profibus features	Device Class 1 and 2
Data exch. functions	Input: Position value Additional parameterised speed signal (readout of the current rotary speed) Output: Preset value
Preset value	With the "Preset" parameter the encoder can be set to a desired actual value that corresponds to the defined axis position of the system.
Parameter functions	Rotating direction: With the operating parameter the rotating direction for which the output code is to increase or decrease can be parameterised.
Diagnose	The encoder supports the following error messages: - Position error - Lithium cell voltage at lower limit (Multiturn)
Default setting	User address 00

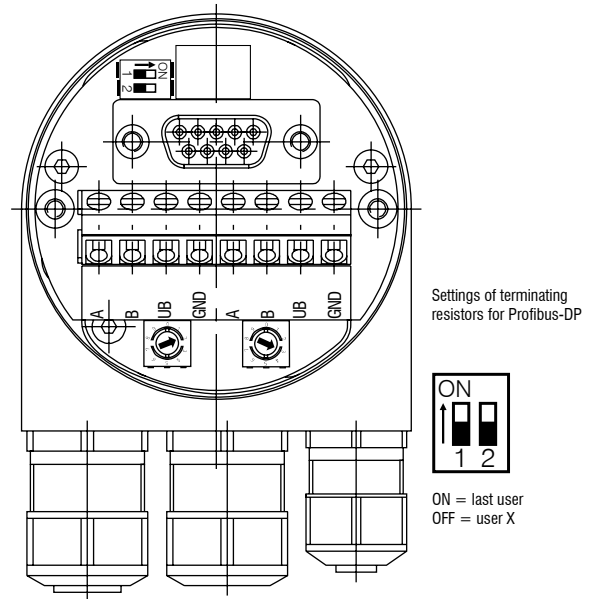
**Settings of user address for Profibus-DP**

Settings of user address for Profibus-DP

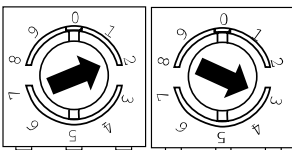
**Contact description Profibus-DP**

A Negative serial data line

B Positive serial data line

UB Supply voltage 10...30VDC

GND Ground contact for UB

(Terminals with the same designation are internally interconnected)

**Signal output**

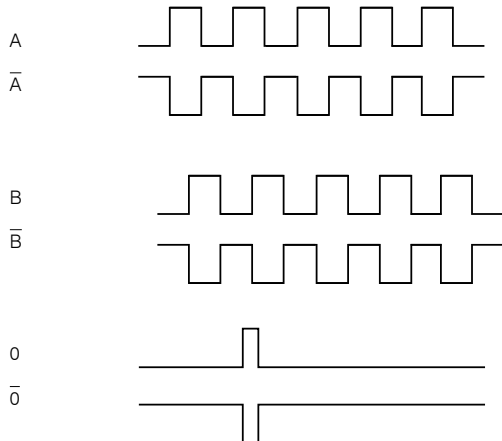

Output TTL	Linedriver (5 VDC)	
Level High	$\geq 2.5V$	(with I = -20mA)
Level Low	$\leq 0.5V$	(with I = 20mA)
Load High	$\leq 20mA$	
Output	A, $\bar{A}$ , B, $\bar{B}$ , O	

Output HTL	Push-pull (10 ... 30 VDC)	
Level High	$\geq UB - 3V$	(with I = -20mA)
Level Low	$\leq 1.5V$	(with I = 20mA)
Load High	$\leq 40mA$	
Output	A, $\bar{A}$ , B, $\bar{B}$ , O	

Output E	Push-pull (5 VDC)	
Level High	UB -2.5V	
Level Low	$\leq 0.5V$	
Load High	$\leq 50mA$	
Output	A, B, O	

Output E830	Push-pull (8 ... 30 VDC)	
Level High	UB -3V	
Level Low	$\leq 2.5V$	
Load High	$\leq 50mA$	
Output	A, B, O	

**Pin assignment TTL, HTL**

Pin	Cable colour	Assignment
Pin 1	pink	B inv.
Pin 2	blue	UB Sense
Pin 3	red	N (zero impulse)
Pin 4	black	N inv. (zero impulse inv.)
Pin 5	brown	A
Pin 6	green	A inv.
Pin 7	-	-
Pin 8	grey	B
Pin 9	-	-
Pin 10	white/green	GND
Pin 11	white	GND Sense
Pin 12	brown/green	UB

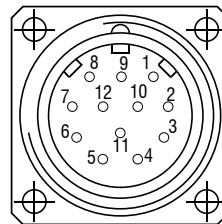

Pin 2 and Pin 12 are internally connected as well as Pin 11 and 10. For cable length > 10m twisted pair wires are required.

**Connection assignment E, E830**

Pin	Cable colour	Assignment
-	white	0V
-	brown	+UB
-	green	A
-	-	A
-	yellow	B
-	-	B
-	grey	0

## High performance sensors made by Micro-Epsilon



Sensors and systems for displacement and position



Sensors and measurement devices for non-contact temperature measurement



2D/3D profile sensors (laser scanner)



Optical micrometers, fibre optic sensors and fibre optics



Colour recognition sensors, LED analysers and colour inline spectrometer



Measurement and inspection systems

