



More Precision

thermoMETER // Non-contact IR temperature sensors





thermoMETER CTLaserM3

Non-contact IR temperature sensor with laser sighting for metals and composite material processing from 50°C

- Measuring range 50°C up to 1800°C
- 2.3µm measuring wavelength for exact measurement in difficult emissivity conditions
- Response time of 1ms
- Double laser marks exact spot size from 0.45mm
- Optical resolution 300:1, 100:1 and 60:1 with selectable focus
- Up to 85°C ambient temperature without cooling, automatic laser switch-off at 50°C, up to 315°C with water cooled housing

Optical specifications thermoMETER CTLaserM3

□ = smallest spot size (mm)

Standard Focus

3LSF	60:1	20	20	20	20	20	19	19	19	18.3	19	25	30	40	53
3HSF	100:1	20	19	18	17	16	15	14	12	11	13	16	20	28	38
3 H1/H2/H3 SF300	300:1	20	17.8	15.5	13.2	11	8.6	6.4	4.8	3.7	5.5	8.6	11.8	17	26.6
distance (mm)		0	150	300	450	600	750	900	1000	1100	1200	1350	1500	1750	2200

Close Focus

3LCF1	60:1	20	11.3	1.4	10.3	17.8	30.4	43	56	81	106	132	157	182	
3HCF1	100:1	20	11	0.85	9.5	16.8	29.1	41.4	53.6	78.2	103	128	152	177	
distance (mm)		0	40	85	120	150	200	250	300	400	500	600	700	800	

Close Focus

3LCF2	60:1	20	14.2	8.4	2.5	10	17.5	25	40	55	70	85	100		
3HCF2	100:1	20	14	7.7	1.5	8.7	16	23	38	52	66	81	95		
3 H1/H2/H3 CF2	300:1	20	13.5	7	0.5	7.3	14	21	34.5	48.2	61.8	75.4	89		
3LCF3	60:1	20	16	11.7	7.6	3.4	9.3	15.1	27	39	51	62	74		
3HCF3	100:1	20	15.5	11	6.5	2	7.5	13	24	35	46	57	68		
3 H1/H2/H3 CF3	300:1	20	15.2	10.3	5.5	0.7	5.8	11	21.2	31.5	41.8	52.1	62.4		
distance (mm)		0	50	100	150	200	250	300	400	500	600	700	800		

Close Focus

3LCF4	60:1	20	18.7	17.3	15.9	14.5	13.1	11.7	10.3	9	7.5	10.6	17	23	29
3HCF4	100:1	20	18.3	16.6	14.9	13.2	11.4	9.7	8	6.3	4.5	7.3	13	19	24
3 H1/H2/H3 CF4	300:1	20	18	16	13.8	11.8	9.7	7.6	5.6	3.5	1.5	3.8	8.6	13.3	18
distance (mm)		0	50	100	150	200	250	300	350	400	450	500	600	700	800

Far Field

3 H1/H2/H3 FF	300:1	20	19	18	17	16	15	14	13.4	12	16.5	24.4	33.4	40	
distance (mm)		0	450	900	1350	1800	2250	2700	3000	3600	4000	5000	6000	6750	

Model	CTLM-3LSF60-C3	CTLM-3HSF100-C3	CTLM-3H1SF300-C3	CTLM-3H2SF300-C3	CTLM-3H3SF300-C3
Optical resolution	60:1	100:1	300:1		
Temperature range ^{1,2}	50 to 400°C	100 to 600°C	150 to 1000°C	200 to 1500°C	250 to 1800°C
Spectral range	2.3µm				
System accuracy ³	±(0.3% of reading + 2°C)				
Repeatability ³	±(0.1% of reading + 1°C)				
Temperature resolution (digital)	0.1°C				
Response time (90% signal) ⁴	1ms				
Emissivity/gain ¹	0.100 to 1.100				
Transmissivity/gain ¹	0.100 to 1.100				
Signal processing ¹	peak hold, valley hold, average; extended hold function with threshold and hysteresis				
Certificate of calibration	optional				
Outputs/analogue	channel 1	0/4 to 20mA, 0 to 5/10V, thermocouple J, K			
Outputs/analogue	optional	relay: 2 x 60VDC / 42VAC; 0.4A; electrically isolated			
Alarm output		open - collector (24V/ 50mA)			
Outputs/digital	optional	USB, RS232, RS485, CAN, Profibus DP, Ethernet			
Output impedances	current output	mA max. 500Ω (with 5 - 36VDC)			
	voltage output	mV min. 100kΩ load impedance; thermocouple 20Ω			
Inputs	programmable functional inputs for external emissivity adjustment, ambient temperature compensation, trigger (reset of hold functions)				
Cable length	3m (standard), 8m, 15m				
Power supply	8 to 36VDC; max. 160mA				
Laser	class II (635nm), 1mW, ON/OFF via controller or software				
Protection class	IP65 (NEMA-4)				
Ambient temperature	sensor: -20°C to 85°C (50°C with Laser ON) controller: 0°C to 85°C				
Storage temperature	sensor: -40°C to 85°C controller: -40°C to 85°C				
Relative humidity	10 to 95%, non condensing				
Vibration	sensor	IEC 68-2-6: 3 G, 11-200Hz, any axis			
Shock	sensor	IEC 68-2-27: 50 G, 11ms, any axis			
Weight	sensor: 600g; controller: 420g				

¹ Adjustable via controller or software

² target temperature > sensor temperature + 25°C

³ ε=1, response time 1s; at ambient temperature: 23 ± 5°C

⁴ with dynamic adaption at low signal levels

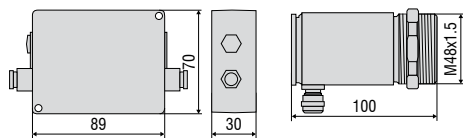

Product identification

CTLM -	3	L	SF60-	C3
Cable length [3m (standard) / 8m / 15m]				
Focus [SF60/100 / CF1 / CF2 / CF3 / CF4]				
Temperature range [L / H]				
Spectral range [2.3µm]				
thermoMETER CTLaserM				

Accessories page 20 - 21

- Mounting bracket
- Air purge collar
- Rail mount adapter for controller
- Water cooled housing
- Interface kit
- Certificate of calibration



LASER LIGHT
 DO NOT STARE INTO BEAM
 CLASS 2 LASER
 IEC 60825-1:2007
 1mW / 630-650nm

CTLaser / CTLaserFAST / CTLaserGLASS / CTLaserM1/M2/M3/M5 / CTLaserCOMBUSTION

Controller

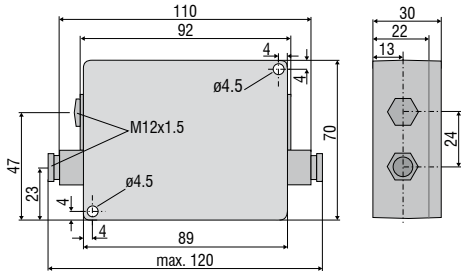

Sensor

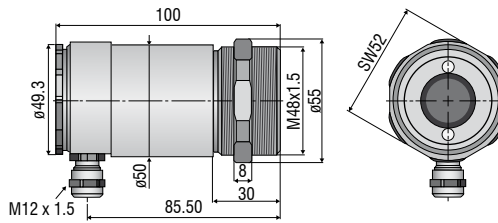

CTratioM1

Controller

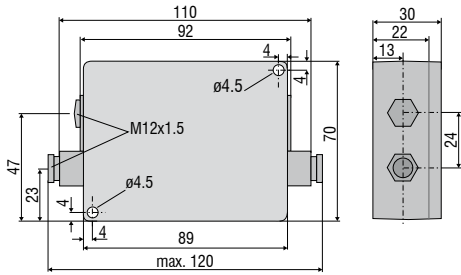

Sensor

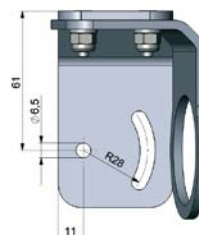
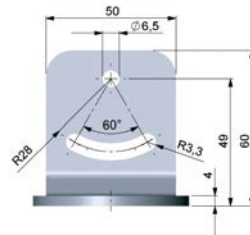
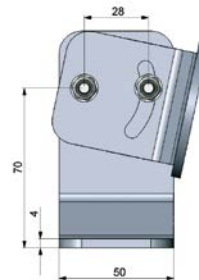
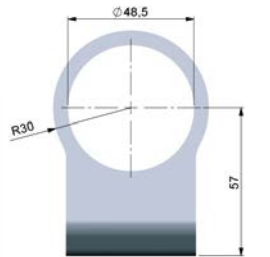
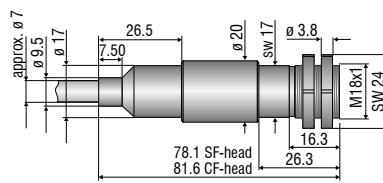

TM-FB-CTL Mounting bracket (fixed);
included in CTL scope of supply

TM-AB-CTL Mounting bracket (adjustable)



TM-W-CTL Water cooled housing

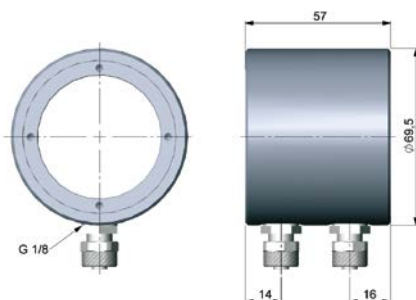

TM-AP-CTL Air purge collar

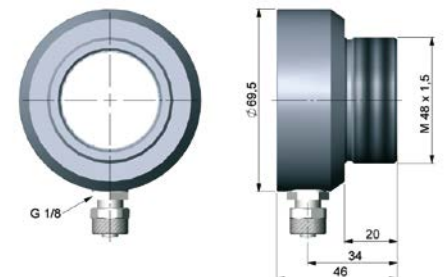

TM-W-CTL Water cooled housing and
air purge collar TM-AP-CTL,
mounted on adjustable mounting bracket TM-AB-CTL

Mechanical accessories		
Art. No.	Model	
2970238	TM-AB-CTL	Mounting bracket, adjustable, stainless steel
2970239	TM-AP-CTL	Air purge collar, stainless steel
2970240	TM-W-CTL	Water cooled housing, stainless steel, for ambient temperatures up to 175°C
2970241	TM-RAIL-CTL	Rail mount adapter for CTLaser controller
2970242	TM-COV-CTL	Closed cover for controller
2970243	TM-MN-CTL	Mounting nut, stainless steel (spare)
2970244	TM-FB-CTL	Mounting bracket, fixed, stainless steel (spare)
2970298	TM-A20UN-CTL	Screw adapter M48x1 on 20UN-2A screw including mounting nut

High temperature accessories for CTLaser		
2970366	TM-J-CTL	Cooling jacket (length 228mm, ø89mm) (conversion kit TM-CONK-CTL is required)
2970374	TM-CONK-CTL	Conversion kit for CTL on axial cable exit, for integration in cooling jacket
2970368	TM-JAB-CTL	Adjustable mounting bracket for cooling jacket
2970369	TM-MF-CTL	Mounting flange M48x1.5 for TM-PF-CTL
2970370	TM-AST300-CTL	Reflection protection tube M48x1.5, 300mm length
2970371	TM-PA-CTL	Pipe adapter M48x1.5
2970372	TM-RM-CTL	Furnace wall mount accessory for CTL (TM-MF-CTL, TM-AST300-CTL and TM-PA-CTL)
2970412	TM-PF-CTL	Pipe flange M48x1.5 for directly mounting a CTL sensor
2970487	TM-CJA-CTL	Cooling Jacket Advanced - universal cooling jacket for CSLaser, CTLaser and CTVideo / CSVideo up to 315°C

Calibration		
2970253	TM-CERT-CTL	Certificate of calibration
2970324	TM-HTCERT-CTL	Certificate of calibration for CTLaser M1-/M2-/M3-/M5-/G-sensors

Interfaces		
2970245	TM-USBK-CTL	USB interface, computer cable, software CompactConnect second cable gland for controller
2970246	TM-RS232K-CTL	RS232 interface, computer cable, software CompactConnect second cable gland for controller
2970338	TM-RS485USBK-CTL	RS485-USB-adapter, incl. PC cable, Software CompactConnect and CTmulti, second cable gland for use with interface board TM-RS485B-CTL
2970248	TM-RS485B-CTL	RS485 interface board incl. second cable gland
2970249	TM-CANK-CTL	CAN-Bus interface; protocol: CANopen Presettings: module address20 (14H), 250kBaud, 0-60°C
2970250	TM-PFBDPK-CTL	Profibus-DPV1 interface for CT selectable with DIN M12 or SUB-D connection
2970251	TM-ETHNK-CTL	Ethernet-Kit: interface board, external Ethernet adapter, software CompactConnect, second cable gland
2970252	TM-RI-CTL	Relay interface: two electrically isolated relays, 60VDC/ 42VAC _{eff} 0.4A

Sensor cables and high temperature cables for CTLaser		
2970374	TM-CONK-CTL	Connector-Kit for cables with connector
4800254.003	TM-CB3C-CTL	Sensor cable with connector (3m)
4800254.003H	TM-CB3HC-CTL	High-temperature sensor cable with adapter (3m)
4800254.008	TM-CB8C-CTL	Sensor cable with adapter (8m)
4800254.008H	TM-CB8HC-CTL	High-temperature sensor cable with adapter (8m)
4800254.015	TM-CB15C-CTL	Sensor cable with adapter (15m)
4800254.015H	TM-CB15HC-CTL	High-temperature sensor cable with adapter (15m)



TM-J-CTL cooling jacket (length 228mm, ø 89mm) with adjustable mounting bracket TM-JAB-CTL; suitable for ambient temperatures up to 180°C

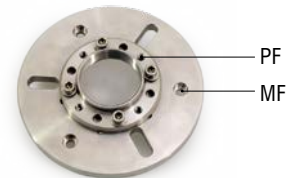

TM-PF-CTL and TM-MF-CTL mounting flange M48x1,5 for directly mounting a CTL sensor



TM-RM-CTL Furnace wall mount accessory for CTLaser / CTratio: TM-MF-CTL, TM-PF-CTL, TM-AST300-CTL and TM-PA-CTL

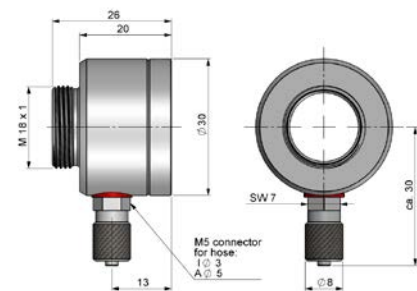

TM-AP-CTR Air purge collar

CTratio		
Art. No.	Model	
2970348	TM-FB-CTR	Mounting bracket, stainless steel, adjustable in one axis
2970395	TM-AP-CTR	Air purge collar, stainless steel
2970373	TM-RM-CTR	Furnace wall mount, stainless steel
2970351	TM-CERT-CTR	Certificate of calibration

Further IR temperature measurement devices from Micro-Epsilon



thermoIMAGER TIM
Compact USB thermal imaging cameras
for precise thermography



thermoMETER CTVideo/CSViduo
IR temperature sensors with
crosshair laser sighting and video output



thermoMETER Handheld
Innovative handheld pyrometer with laser
sighting for inspection and maintenance

