

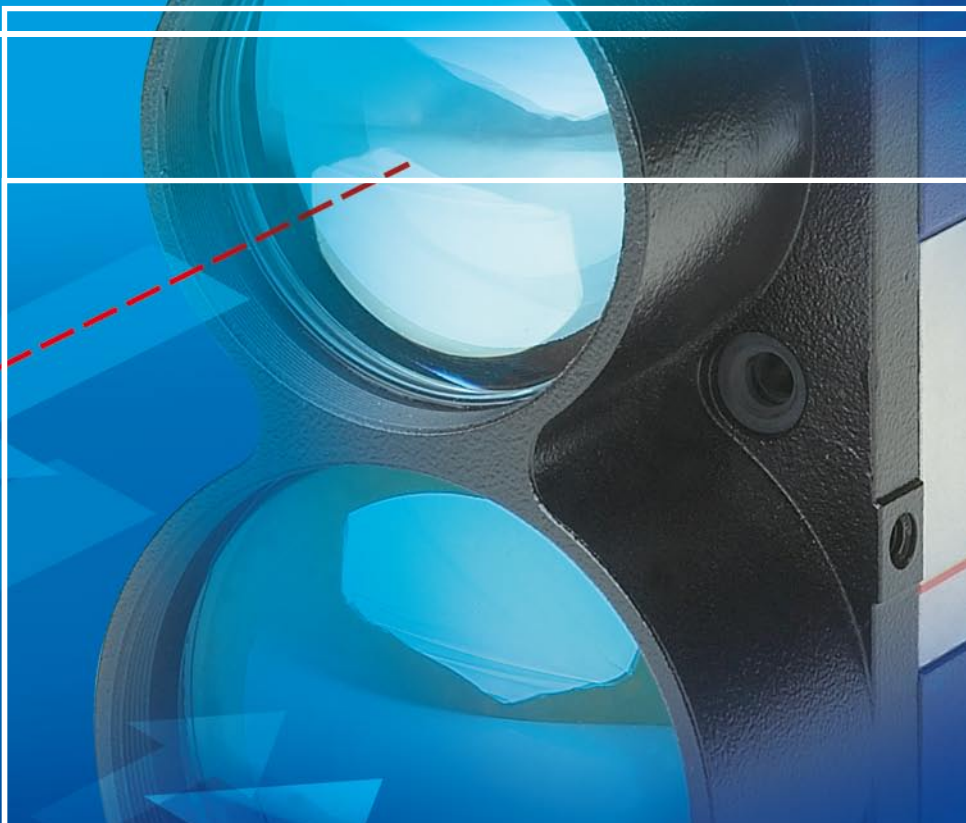

More Precision.

optoNCDT ILR
Laser distance sensors





MICRO-EPSILON
optoNCDT



Advantages

- Measuring range 500m in diffuse reflecting surfaces, up to 3000m with reflector
- Distance and speed measurement
- Integrated heating
- For fast measuring events
- Easy installation
- Accessories for harsh environments

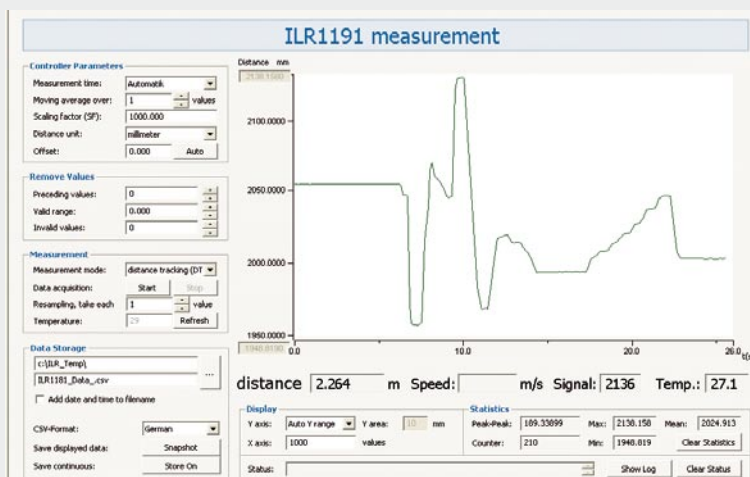
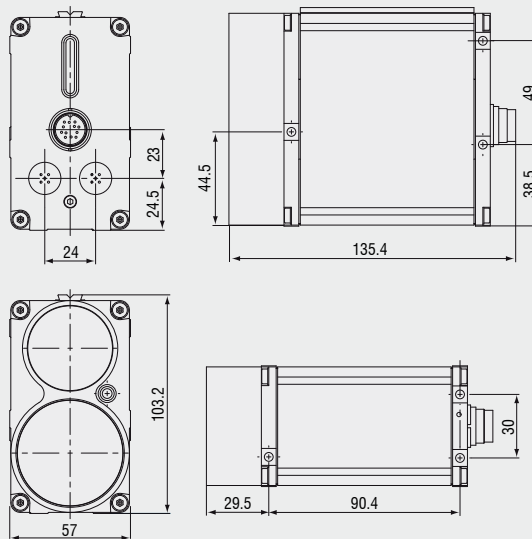
Sensors in the optoNCDT ILR 1191 series are optoelectronic sensors for non-contact distance and speed measurement for industrial use. The sensor is designed for very large measuring ranges, with and without reflector. Due to the very high measuring rate of the sensor, moving objects can be measured easily. The sensor operates according to the laser pulse runtime principle and is therefore particularly well suited to applications with large distances. Commissioning of the sensor is straightforward due to a variety of interfaces and easy mounting options. The optoNCDT ILR 1191 is fitted with an integrated heater for outdoor use. A sighting device is also integrated for alignment.



Configuration and measurement software for ILR1191

Model		ILR1191-300
Measuring range ¹⁾	black 6%	1 ... 150 m
	grey 10%	0.5 ... 300 m
	white 90%	0.5 ... 500 m
	reflector	0.5 ... 3000 m
Speed		0ms ⁻¹ ... 100ms ⁻¹
Linearity ²⁾		±20mm (at measurement output 100Hz) ±60mm (at measurement output 2kHz)
Resolution		1mm
Repeatability		≤20mm
Response time	distance measurement	0.5ms
	speed measurement	12ms
Laser class	measuring laser	905 nm, laser class 1
	sighting laser	635 nm, laser class 2
Operation temperature		-40°C ... +60°C
Storage temperature		-40°C ... +70°C
Limit outputs		QA / QB (max. 200 mA)
Switching points		free adjustable
Switching hysteresis		free adjustable
Trigger input		trigger edge and trigger delay programmable, trigger pulse max. 30 V
Serial interface		RS232 and RS422 with 1.2kBaude ... 460.8kBaude SSI interface (RS422), 24Bit, Gray-encoded 50kHz ... 1MHz
Profibus		RS485, 9.6 kBaude ... 12MBaude
Operation mode		single / continuous measurement, external triggering (adjustable near field elimination), speed measurement
Analogue output		4 ... 20mA (16 Bit DA)
Temperature stability		≤50ppm / °C
Supply		10 ... 30 V DC
Max. consumption		<5W without heating, 11.5W with heating
Connection		1 x 12-pin M16, 2 x 5-pin M12 B-coded
Protection class		IP 67
Material (housing)		aluminium strangeness profile, powder-coated
Weight		800 g (depends on equipment)
Vibration/Shock		500g, 0.5ms, 1 shock / axis (DIN ISO 9022-30-08-1)
		10g, 6ms, 1000 shocks / axis (DIN ISO 9022-3-31-01-1)
EMV		EN 61000-6-2, EN 55011
Accessoires		page 16 - 17

¹⁾ depending on target reflectivity, stray light effects and atmospheric conditions
²⁾ with statistical spread of 95%

Product identification

ILR 1191 - 300 (0 x)

- Serial interface
 1= RS232
 2= RS422
 3= RS232 + SSI
 4= RS232 + Profibus

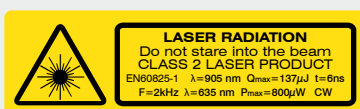

optoNCDT ILR 1191 use a semiconductor class 1 laser (operating mode) and a semiconductor class 2 laser (setup mode). With these classes no protection is needed.

Spot diameter ILR1191

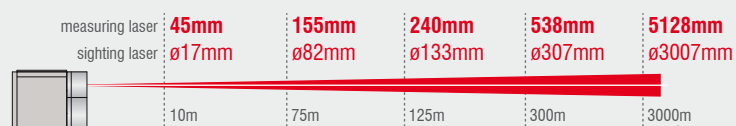

Applications

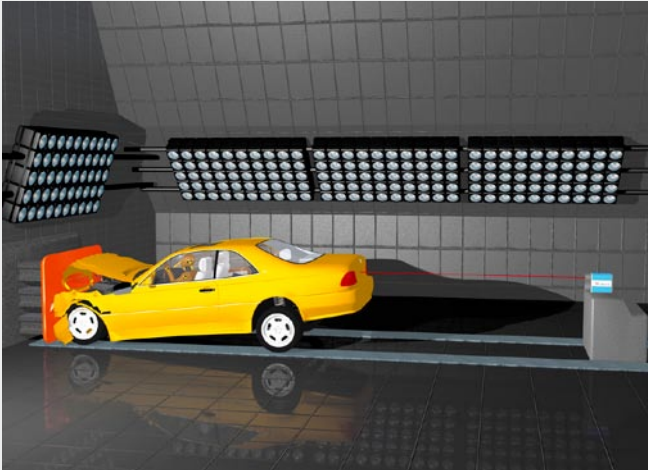

Speed measurement in the crash test

During the acceleration of vehicles in the crash test, an ILR1191 measures the impact speed and the deformation of the test vehicle.



Position measurement on gantry cranes

Numerous measurement tasks on gantry cranes must be performed: Positioning of the trolley, detection and dimensioning of containers and monitoring of the minimum clearance between the cranes. The ILR1191 with a very large measuring range and low response time is designed for these measurement tasks.



Level measurement in container, tanks and silos

Depending on the accuracy demanded, the filling level of silos is found at up to four points. The level is determined from these distances.

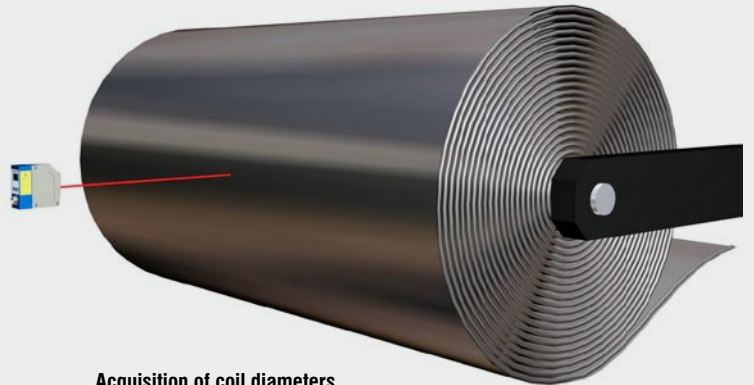

Acquisition of coil diameters

The quantities of steel, paper and fabric wound on and off are monitored via the acquisition of coil diameters using laser probes.