



More Precision.

capaNCDT

High resolution capacitive displacement sensors and systems.





System structure

capaNCDT 6300/6310 is a single-channel system with modular designed signal conditioning electronics installed in an aluminium housing. Using three-point linearisation, the user can also compensate on site for insulator materials. The pre-amplifier for the 6300 series is integrated in the controller. An external pre-amplifier is used for the 6310 series whereby the cable length can be extended up to 20m, enabling very large distances between sensor and controller. The capaNCDT 6300/6310 series is used for demanding measurement tasks and can be used with all capaNCDT sensors.

- Nano resolution
- High zero point stability & accuracy
- Unmatched temperature stability
- Any target, also insulator measurement
- Measuring system for high requirements
- Suitable for all sensors
- Robust design

A measuring system consists of:

- capacitive displacement sensor
- sensor cable
- signal conditioning electronics

Accessories:

- power supply cable
- power supply
- synchronisation cable
- signal output cable

Special tuning

Special tuning is required for cable lengths above 1m (standard cable length is 1m)

Pre-amplifier CP6001



Block diagram

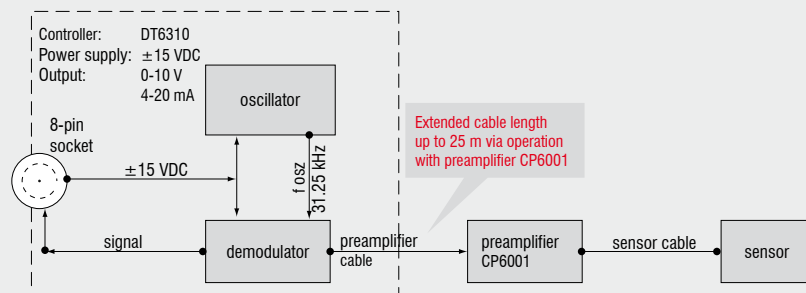
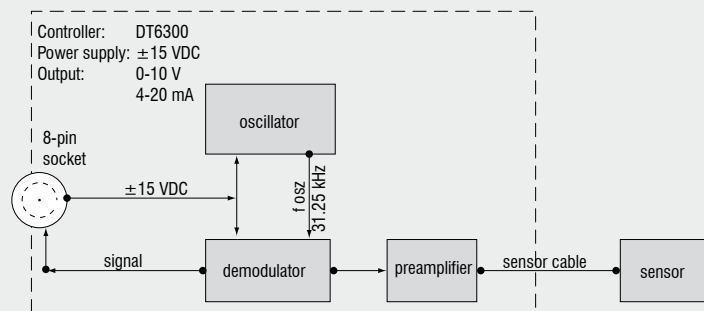

Controller type	DT6300/DT6310
Resolution static	0.001 % FSO
Resolution dynamic	0.01 % FSO (8kHz)
Bandwidth	8kHz
Bandwidth adjustable	20Hz / 1kHz / 8kHz
Linearity	±0.2 % FSO (all sensors interchangeable without calibration) Option LC: ±0.1 % FSO (tuned to one sensor)
Max. sensitivity deviation	±0.1 % FSO
Long term stability	≤0.02 % FSO / month
Synchronous operation	yes
Insulator measurement	yes
Temperature stability	±0.01 % FSO / °C
Temperature range (operation)	+10 ... +50°C
Temperature range (storage)	-10 ... +75°C
Supply	±15 VDC (±2 %) / ±150mA
Output	0 - 10 VDC (max. 10mA short circuit proof) 4...20mA (load max. 500Ω)
Suitable for sensors	all sensors
Sensor cable standard	≤1m
Sensor cable (matched)	up to 4 m

Options

2982010 EMR2C DT6300
extended measuring range (factor: 2)

2982012 RMR 1/2C DT6300
reduced measuring range (factor: 1/2)

2982014 ECL2C DT6300
special tuning for 2m sensor cable

2982016 ECL3C DT6300
special tuning for 3m sensor cable

2982027 ECL4C DT6300
special tuning for 4m sensor cable

2982018 LC option DT63xx

2982011 EMR2P CP6001
extended measuring range (factor: 2) in combination with DT6310

2982013 RMR 1/2P CP6001
reduced measuring range (factor: 1/2) in combination with DT6310

2982015 ECL2P CP6001
special tuning for 2m sensor cable in combination with DT6310

2982017 ECL3P CP6001
special tuning for 3m sensor cable in combination with DT6310

2982026 ECL4P CP6001
special tuning for 4m sensor cable in combination with DT6310

Controller

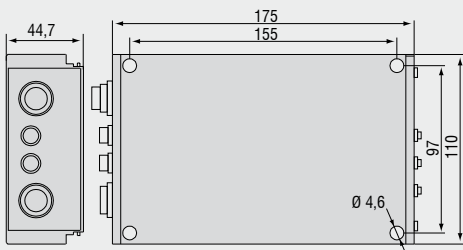

CP6001 Capacitive pre-amplifier

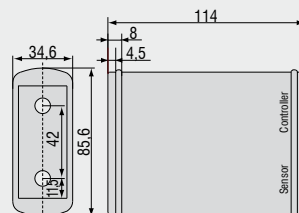

Mounting adapter für CP6001

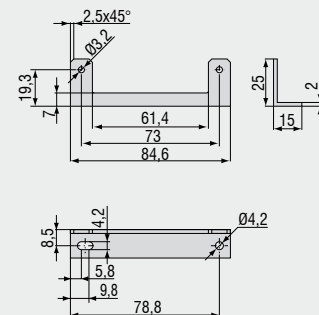

Pre-amplifier cable CA5 / CAx

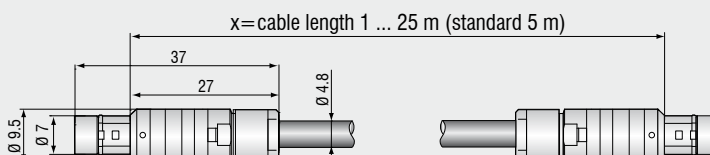

High performance sensors made by Micro-Epsilon



Sensors and systems for displacement and position



Sensors and measurement devices for non-contact temperature measurement

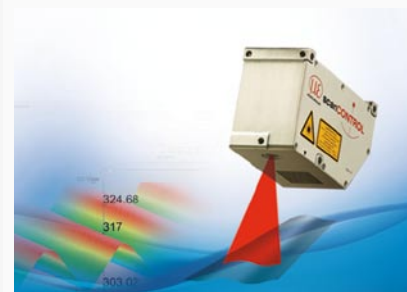

2D/3D profile sensors (laser scanner)

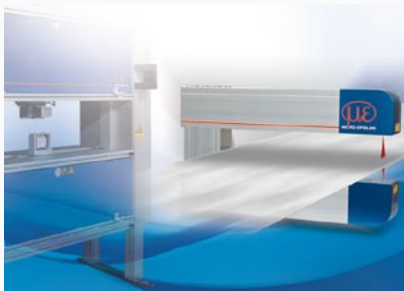

Measurement and inspection systems for quality assurance



Optical micrometers and optical fibers



Color recognition sensors and LED analyzers