

# Distance Sensor M9-i

Laser sensor  
with integrated electronic system

Triangulation digital

- compact
- Measurement on many different surfaces possible

- Measuring
- Controlling
- Monitoring



**M9-i-2/10/20/50/100/200/250VT**  
weight 550 g, cable length 0.25 m

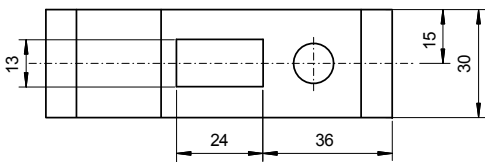
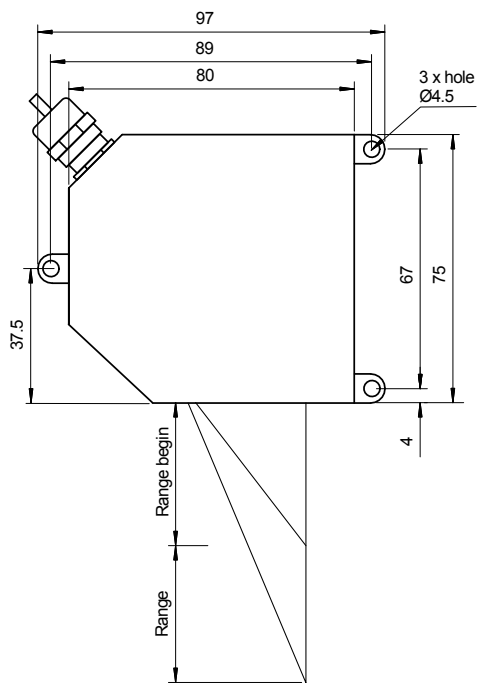

Connector (sensor side)

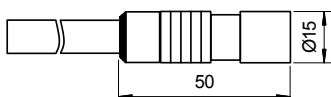

**M9-i-40/500/750**  
weight 600 g, cable length 0.25 m

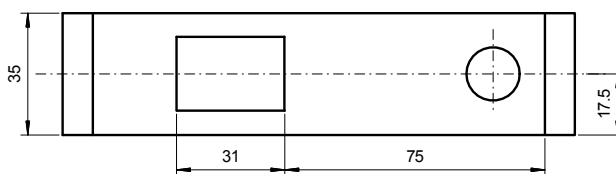
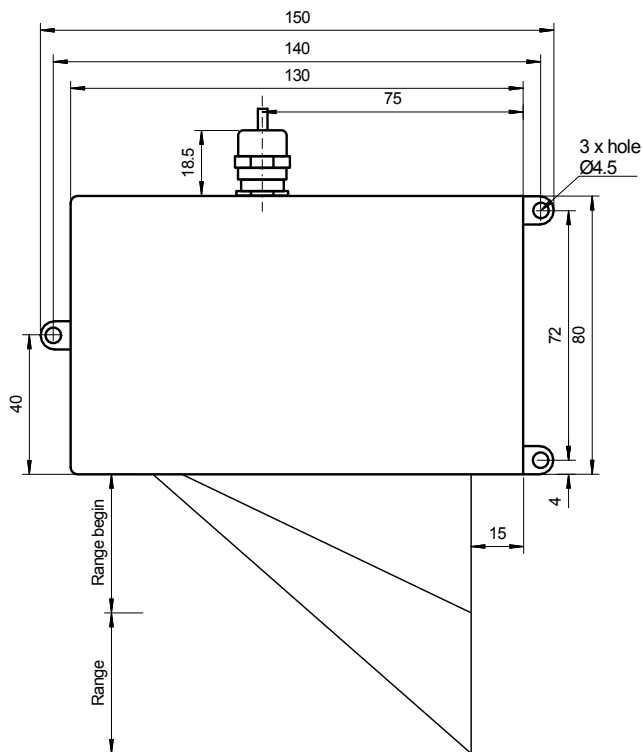

Connector (sensor cable)

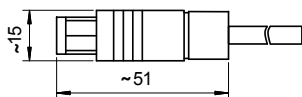

# Laser Sensor M9-i

For cramped confines

Sensor	M9-i/ 2	M9-i 10	M9-i/ 20	M9-i/ 40	M9-i/ 50	M9-i/ 100	M9-i/ 200	M9-i/ 250VT	M9-i/ 500	M9-i/ 750
Range [mm]	2	10	20	40	50	100	200	250	500	750
Range begin [mm]	24	30	40	175	45	70	70	70	200	200
Linearity ± [µm]	2	8	16	32	40	80	200	630	400	750
Resolution* [µm]	0.1	0.5	1.5	4	3	6	12	50	30	50
Light spot diameter** [µm]	35	50	45	210	55	60	1300	1500	1500	1500
Light source	Laser, wave length 670 nm, red visible, <1 mW									
Laser protection class	2 (DIN EN 60825-1:2001-11)									
Measurements	selectable: 4 ... 20 mA / 0 ... 10 V; optional: RS 422 / USB									
Output										
Switching outputs	1x error or 2x limit (each programmable)									
Switch input	laser ON-OFF / zero									
Operation	via touch screen on sensor or via PC with sensorCONFIG									
Bandwidth	2.5 kHz / 1.25 kHz / 625 Hz / 312.5 Hz (adjustable)									
Temperature drift [% of range / K]	0.03	0.01						0.03	0.01	
Permissible ambient light at 2 kHz [lx]	10,000							15,000	10,000	
Vibration***	2 g / 20 ... 500 Hz									
Shock***	15 g / 6ms									
Operating temperature	0° ... +50°C									
Storage temperature	-20° ... +70°C									
Electromagnetic compatibility (EMC)	EN 61000-6-3 / EN 61000-6-2									
Protection class	IP 65									
Supply	24 VDC (11 ... 30 VDC), max. 150 mA									

\* Measurement at 2,5 kHz, no averaging

\*\* Values apply for midrange

\*\*\* M9-i-250VT: 20 g, vibration and shock resistant sensor model for use on vehicles

All specifications apply for a diffusely reflecting matt white ceramic target

## Delivery:

- Sensor with connecting cable (0.25 m) and cable connector
- Manual

## Accessories:

- Sensor cable extension\* (3 or 10 m)
- Interface and supply cable (RS 422)
- USB supply and output cable (3 m), including power supply unit
- Power supply
- Interface card RS 422
- Protection housing

\* necessary at first order