

# High Performance Digital Laser Doppler Vibrometer Vector-Master



OptoMET laser Doppler vibrometers (LDV) are very fast and easy-to-operate vibration measuring instruments. They are used for precise, non-contact, and non-reactive measurements of mechanical and acoustic parameters such as vibration displacement amplitude, velocity, and acceleration.

Thanks to our innovative digital signal processing technology and the highest optical sensitivity, our instruments provide quick and simple vibration measurements of even the most challenging systems, including high vibration frequencies, large working distances, small vibration amplitudes, high linearity, and high accelerations or velocities, ...

With these unique properties, OptoMET vibrometers can be used for numerous applications, ranging from microsystems and aerospace, from research and development laboratories to automated industrial applications.

## Highest performance

The Vector Master pushes the envelope of modern digital signal processing and sets a new standard for real-time, digital laser Doppler vibrometers. This instrument has a dynamic range of 2.5 nm/s to 10 m/s (9 decades) and  $5 \times 10^{-7}g$  to  $3,2 \times 10^7g$  (14 decades) as well as a bandwidth of 10 MHz, combined with a displacement resolution of 15 pm.

These technical data make the Vector Master the ideal tool for challenging research and development tasks.

## Performance characteristics:

- Maximum vibration velocity 10 m/s
- 14 velocity measuring ranges
- Frequency range DC to 10 MHz
- Maximum permissible acceleration of the measure object  $32 \times 10^6g$
- Ultrafast digital signal processing (ultraDSP)
- High resolution of the vibration velocity up to  $2.5 \text{ nm s}^{-1}/\sqrt{\text{Hz}}$
- Variable working distances (45 mm to >100 m) with 4 different quick-change objective lenses
- Excellent linearity and measuring accuracy
- Compact design of the optics (interferometer) and the electronics (decoder) in one housing
- Easy-to-operate user interface, color touch display, rotary knobs and buttons to select the measuring ranges and settings
- Very legible display of the signal level
- 3 analog voltage outputs via standard BNC connectors
- Visible, eye-safe laser beam  $\leq 1 \text{ mW}$ , class II

## Features

### Ultrafast digital signal processing (ultraDSP)

A Laser Doppler vibrometer with digital high-speed signal processing provides precise, high-resolution data enormously fast. It is thus far superior to conventional analog decoder solutions used for vibration measurement.

OptoMET developed the ultraDSP technology for laser vibrometry and thus achieved excellent performance specifications, with displacement and velocity resolutions of up to 15  $\mu\text{m}$  and 2,5  $\text{nm s}^{-1}/\sqrt{\text{Hz}}$  respectively, excellent linearity, and an extremely large frequency bandwidth of up to 10 MHz.

### *ultraDSP* Advantages:

- Excellent speed- and displacement resolution
- High upper frequency limit
- Lower frequency limit DC
- Excellent linearity
- High measurement accuracy
- High aging stability
- "low noise" digital signal demodulation
- Variable working distances
- Insensitive to surface roughness / color

### Excellent optical sensitivity

Low-noise signal converters/input stages, a highly precise heterodyne interferometer, and fast objective lenses allow measurements of almost any surface, irrespective of color, temperature, and roughness.

### Measuring with light

The instrument uses highly visible red laser light with a wavelength of 633 nm. It measures picometer-scale vibrations and delivers true measured values without an additional sensor mass. The laser spot can be focused to a diameter of about 25  $\mu\text{m}$  so that very small structures can be measured.

### Always the correct working distance

From a microsystem to a high-rise building: the objective lenses can be exchanged in a matter of seconds so that the object can be measured at the appropriate working distance: from 45 mm to more than 100 meters.

There is an optional telescopic sight to facilitate fast setup when measuring at a large distance.

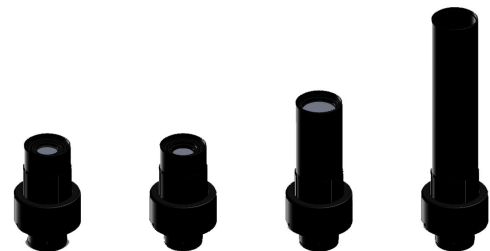

### Perfect handling

The complete vibrometer has a very compact design. The laser, interferometer, controller and decoders for displacement, velocity, and acceleration, as well as the user interface are all accommodated in a portable housing. The instrument has a 24 V DC connection as well as an external 110/230 V AC power supply unit and can thus be used in the laboratory, in production, and in the field. It also has a touchscreen and separate rotary knobs for intuitive and user-friendly operation.



## General data

Measured quantity	velocity, displacement and acceleration
Signal processing	Digital (OptoMET UltraDSP)
Frequency range	DC - 10 MHz
Velocity-Decoder	D-VD-5
Velocity measuring ranges	1 mm/s - 10 m/s
Number of velocity measuring ranges	14 (0.001 / 0.002 / 0.005 / 0.01 / 0.02 / 0.05 / 0.1 / 0.2 / 0.5 / 1 / 2 / 5 / 8 / 10 m/s)
Resolution of the vibration velocity	2.5 nm s <sup>-1</sup> /√Hz
Displacement-Decoder	D-DD-5
Displacement measuring ranges	1 μm - 100 mm
Number of displacement measuring ranges	16
Resolution of the vibration displacement	15 pm
Acceleration-Decoder	D-AD-5
Acceleration measuring ranges	1.6 g - 32000000 g
Number of acceleration measuring ranges	14
Resolution of the vibration acceleration	0.5 μg
Output signal	Analog, standard BNC connectors
Output voltage range	± 2 V
Source impedance	50 Ohm
Working distances	Variable working distances (45 mm bis >100 m), 4 different objective lenses
Laser wavelength	633 nm, visible, red laser beam
Laser safety class	Output power: 1 mW, class II, eye-safe
User interface output	color screen 3.5" + 20 segment LED bargraph
User interface input	touch screen, knobs with push-button, key switch (power), switch (laser ON/OFF)
Operating temperature range	+5 bis 30°C
Dimensions	length x width x height (excluding handle and lens): 370 x 120 x 100mm
Weight	11 kg
Power supply	110 -240 V AC (50-60Hz) oder 24 V DC

## Objective lenses

Item number	Description
OBJ-SR	Short Range objective lens, working distance: 45 mm ... 5 m
OBJ-MR	Middle Range objective lens, working distance: 150 mm ... 10 m
OBJ-LR	Long Range objective lens, working distance: 500 mm ... 100 m
OBJ-SLR	Super Long Range objective lens, working distance: 1700 mm ... 200 m

## Objective lenses technical data

Objective lenses	OBJ-SR Short Range	OBJ-MR Mid Range	OBJ-LR Long Range	OBJ-SLR Super Long Range
Focal length (mm)	25	50	100	200
Min. stand-off distance (mm)	45	150	500	1700
Spot size in μm at				
45 mm	25			
150 mm		30		
500 mm			65	
1700 mm				85

## Setup

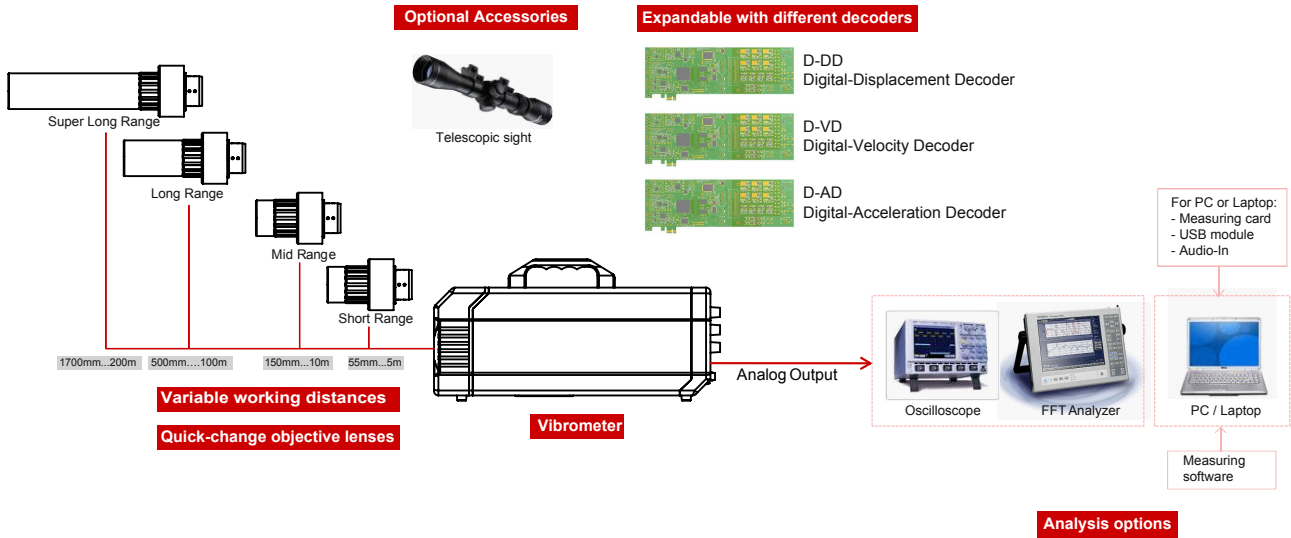

## Dimension

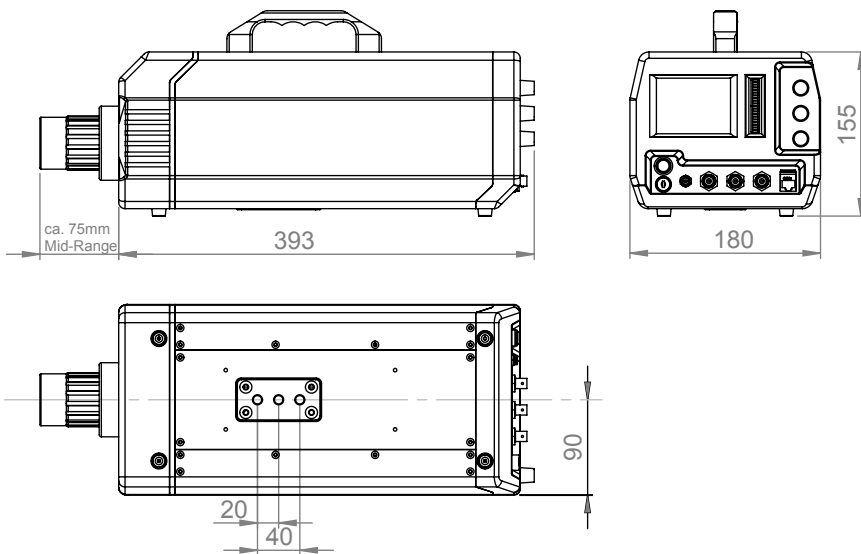

## Laser label



DO NOT STARE INTO BEAM  
CLASS 2  
visible, red laser beam  
output power:  $\leq 1$  mW.

## Indicators / operating

1	Touch screen LCD 3.5-Inch
2	Signal Level
3	Displacement measuring ranges
4	Velocity measuring ranges
5	Acceleration measuring ranges
6	Ethernet
7	Output acceleration
8	Output velocity
9	Output displacement
10	Power
11	Lock
12	Laser

