

More Precision

confocalDT 2451/2471



System structure

confocalDT 2451/2471 are the latest high end controllers of the confocal measurement technology offered by Micro-Epsilon. The latest models achieve measurement rates of 10kHz using a white light LED and 70kHz using a xenon light source due to a very good signal-to-noise ration.

The new active exposure regulation of a line allows a precise and fast surface compensation at dynamic measurement processes on different surfaces.

Due to a comfortably designed web interface the total sensor configuration can be effected avoiding any additional software. The data output is effected via Ethernet, EtherCAT, RS422 or analogue output.

The confocalDT 2451/2471 are applied in challenging measurement tasks regarding the distance and thickness measurement and can be used with all sensors belonging to the optoNCDT24xx series.

The transmission of optical signals is performed via an optical fibre (sensor, controller, xenon light source).

Block diagram

Controller IFC2471

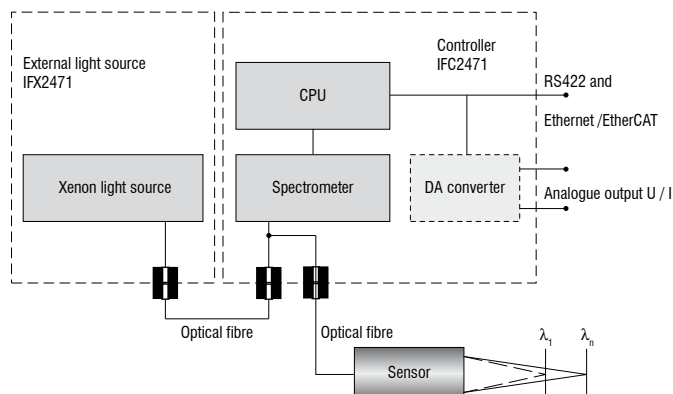

Features

- One of the fastest confocal controllers worldwide
- Adjustable measuring rate up to 70kHz
- Very fast surface compensation due to exposure time regulation
- Configuration via Web-Interface
- Interface: Ethernet, EtherCAT, RS422, analogue
- Robust design with passive cooling

A measuring system optoNCDT2451 consists of:

- Sensor IFS240x
- Controller IFC2451

A measuring system optoNCDT2471 consists of:

- Sensor IFS240x
- Controller IFC2471 (for external light source)
- Xenon light source IFX2471

Option:

- Integrated Multipeak software for 5 Layers

confocalDT 2451/2471 Technical data

Controller	IFC2451/IFC2471		
Light source	IFC2451: internal white LED; IFC2471: external XENON light source IFX2471		
Measuring rate [kHz]	IFC2471: adjustable 70 / 50 / 25 / 10 / 5 / 2.5 / 1 / 0.3kHz IFC2451: adjustable 10 / 5 / 2.5 / 1 / 0.3 / 0.2 / 0.1kHz		
Storage	up to 20 calibration tables for different sensors, menu selection		
Controller Inputs / Outputs	Power supply +24VDC, <u>not</u> galvanically isolated Sync-In/Trig-In, Sync-Out Error1-Out, Error2-Out Encoder (3x A, B, Index) EtherCAT/Ethernet, galvanically isolated RS422, galvanically isolated Analogue power, voltage, galvanically isolated External light source: temperature, light-bulb exchange (only IFC2471)		
Operating elements, controller display	On/Off rocker switch Button for dark alignment (as well as for reset to factory setting after 10s) 4x LED for intensity, range, status, supply voltage		
Supply voltage, power consumption	Controller: 24VDC \pm 15%, approx. 10W Xenon light source: 90 ... 265VAC, approx. 100W		
Housing	Aluminium case for DIN rail mounting		
Ambient conditions	Sensoren	Controller	Xenon light source
Protection class	IP 64	IP40	IP40
Operating temperature	5°C to 50°C non-condensing	5°C to 50°C, linearity at 25 \pm 5°C	5°C to 40°C
Storage temperature	-20°C to 70°C	-20°C to 70°C	-20°C to 70°C
Permissible ambient light	30,000lx		
Safety; EMC Interference emission Interference resistance	CE; UL certified EN 61 000-6-3 / DIN EN 61326-1 (class B) EN 61 000-6-2 / DIN EN 61326-1		
Optical fibre cable length	Sensor	3m (cannot be detached on miniature and hybrid sensors, but on standard sensors)	
	Xenon light source	1m	
	Connector type	E2000	
Maximum cable length EtherCAT, Ethernet Supply, RS422, Sync./Error Analogue Encoder	All cables are shielded CAT5E; cable length < 100m < 30m < 30m < 3m		

Controller IFC2471

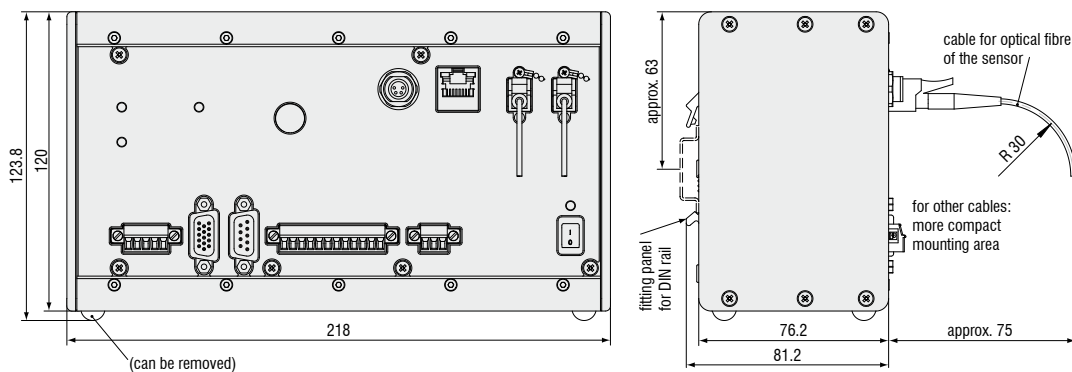

Micro-Epsilon

info@micro-epsilon.com
www.micro-epsilon.com

info@micro-epsilon.co.uk
www.micro-epsilon.co.uk

me-usa@micro-epsilon.com
www.micro-epsilon.com

certified DIN EN ISO 9001 : 2008
modifications reserved / Y9761398-A011091DGO

